

CPH2-N Spec-sheet



Industrial NB IoT – Cat-M1 Operated Low Power pH, ORP and Temperature Sensor

- Compatible with most standard communication Protocols (UDP, LwM2M, MQTT, NIDD, etc.)
- Wide range of industrial applications
- High accuracy
- Designed to meet outdoor applications
- Long-term durable performance in harsh environment
- Ultra-low power
- Pre-configured with no need of programming or hardware setting



TECHNICAL SPECIFICATION

pH Sensor

• Measurement Range	0-14	pH
• Accuracy	±0.1	pH
• Resolution:	0.01	pH

ORP Sensor

• Measurement principle	Combined electrode (ORP/reference) Platinum tip, Ag/AgCl AgAgCl. Gelled reference (KCl)	
• Measurement Range	-1000 to +1000	mV
• Resolution	0.1	mV
• Accuracy	±2	mV

Temperature Sensor

• Measurement principle	NTC	
• Measurement Range	0 to +50	°C
• Resolution	0.01	°C
• Accuracy	±0.5	°C
• Storage Temperature	0 to +50	°C

Power

• Power Supply:	Built-in Replaceable Lithium Battery External Power (option)	
• Rated Voltage	3.6	V
• Battery Lifetime:	Typ. 20,000+ readings / 5,000+ transmission (connected to ellenex platform and standard network quality)	

Physical Specification

• Materials:	Sensor Head: PVC, DELRIN, special pH glass, platinum, polyamide, cable: Coaxial armoured, Polyurethane Enclosure: POM	
• Max. Pressure on Sensor Head:	5bar	
• Weight:	~900 (for 3m cable)	g
• Protection Rate:	IP68 for sensor head and IP66 or IP68 and UV protected enclosure	

CPH2-N Spec-sheet

Communication

• Communication Standards	Cat-NB1 (NB-IoT) Cat-M1 (option of back support by GPRS)
• Communication Bands	B1/B2/B3/B4/B5/B8/B12/B13/B18/B19/B20/B26/B28 and B39
• Data Rates:	Cat-M1: 375Kbps (DL)/375Kbps (UL) NB-IoT: 32Kbps (DL)/70Kbps (UL)
• TX Power:	23dBm
• Min Receiver Sensitivity:	Cat-M1: -107dBm NB-IoT: -113dBm
• Antenna:	Internal (Default)/ External (customised options available)
• Optional Features:	<ul style="list-style-type: none"> • Attach without PDN (Packet Data Network) • Support for IPV6 • SMS communication • Mobility support (Cat-M1 only)

NETWORK CONNECTION AND VISUALISATION

Network Integration

Pre-configured or configurable to all main narrow band networks (3, A1, AT&T, China Mobile, DU, Etisalat, KPN, M1 Singapore, Optus, Orange, Proximus, Spark, Sprint, Swisscom, Telefonica, Telstra, T-Mobile, Verizon, Vodafone, 1NCE, Emnify and any other network)

Visualization and Data Management

Ellenex white label microservice platform and Integratable to all main IIoT platforms directly or through the API (AWS, Azure, PTC ThingWorx, Bosch IoT, Cisco Jasper & Kinetic, Sierra Numerex, MathWorks ThingSpeak, GE Digital Predix, LandisGyr, Siemens MindSphere, Cumulocity, myDevices, Ubidots, TagoIO, HPE IoT and any other major IoT platform).

Ellenex Platform Main Features

- Encrypted ultra-low power communication protocol
- Advanced device inventory
- Integration APIs for enterprise systems
- Multi-tenant role-based access control
- Data export and import
- White-label platform for enterprise runs on private account
- Variable alarm setting for high and low thresholds and multi-channel alerting
- Sampling and transmission interval configuration
- Transmission condition configuration
- Other configurations and customization available on request



Encrypted & ultra-low power



Integratable



Dynamic alerting



Multi-tenant



Scalable

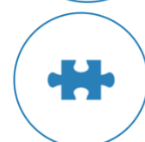



Composable & API first

CPH2-N Spec-sheet

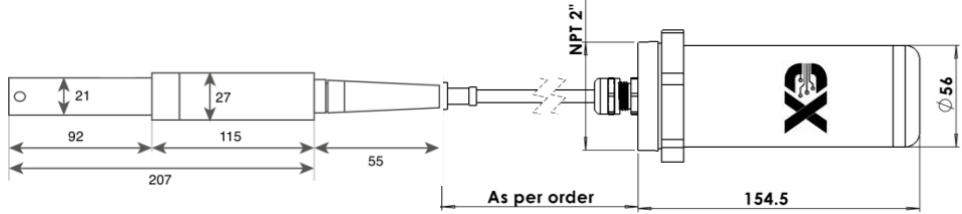

MODEL GUIDE

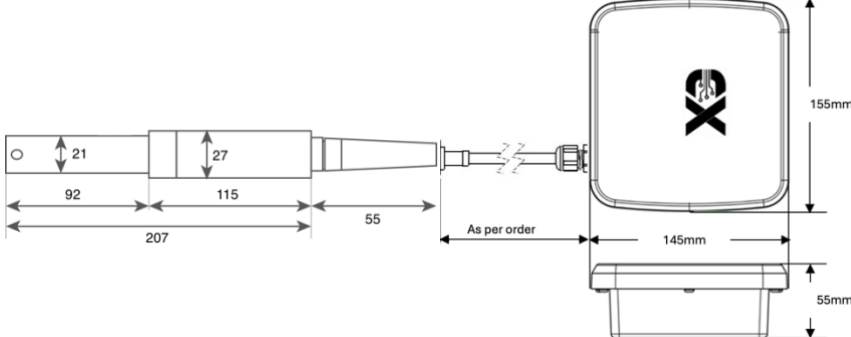
Model	Drawing:
<p>C Model:</p> 	 <p>IP68 sensor head, connected to POM enclosure IP68 enclosure: with cable gland, without on/off switch, and with internal antenna IP66 enclosure: with sensor connector, on/off switch, and external antenna</p>
<p>E Model:</p> 	 <p>IP68 sensor head, connected to IP65 ASA enclosure with on/off switch</p>

INDUSTRIES



Water & Wastewater



Agriculture & Farming



Oil & Gas



Marine & Oceanography



Mining & Construction



Environmental Monitoring

APPLICATIONS

- Bore Hole Mineral Level
- Water Resources
- Surface Water, Rivers, and Catchments
- Sea water
- Wastewater Tanks
- Industrial Wastewater
- Regulatory Automated Reporting
- Drinking Water

CPH2-N Spec-sheet

ORDERING CODE

CPH2-N								
Communication Type								
B: NB-IoT					C: Cat-M1			
Measurement range								
S: pH: ~ 2 - ~12, ORP: -1000 to +1000, Temp: 0 - +50°C							Others	
Enclosure								
C: Cylindrical				E: Rectangular				
Cable Length								
S: 3m					Others			
Device Activation								
S: On/Off switch						X: No switch (Always on)		
Antenna								
I: Internal				E: External				
Options								
(on request) ¹								
CPH2-N	B	S	C	S	S	I		

Sample Product Code:

- CPH2-N-B-S-C-S-S-I

NB IoT pH sensor, measurement range of 2-12, In cylindrical enclosure, standard cable length, with on/off switch and internal antenna.

¹) Product Options:

- **EPB:** sensor with external power supply connector 12V supply with internal battery backup (only for E type enclosure. Adaptor is not included)
- **HG:** high-gain external antenna
- **HCB:** high-capacity battery (only for E type enclosure)