

PDT2-N Spec-sheet



NB IoT – Cat-M1 Operated Low Power Differential Pressure Transmitter With Built-in Temperature Sensor for Pressure and Flow Measurement of Gas Media

- Compatible with most standard communication Protocols (UDP, LwM2M, MQTT, NIDD, etc.)
- Pressure range of 500Pa (or others)
- Wide range of industrial applications
- High accuracy and Ultra-low power
- Designed to meet outdoor applications
- Compatible with air and other non-conductive and non-corrosive Media



TECHNICAL SPECIFICATION

Sensor

• Range:	Standard Range: $\pm 500, \pm 125$	Pa
• Accuracy: (combined linearity, hysteresis, repeatability)	± 2 (typ.)	%Span
• Resolution:	± 0.02	%Span
• Pressure Reference:	Bi-directional Differential	
• Temperature Accuracy:	$\leq \pm 2$	$^{\circ}\text{C}$
• Temperature Coefficient of Zero:	$\leq \pm 0.05$	%FS/ $^{\circ}\text{C}$
• Temperature Coefficient of Span:	$\leq \pm 0.05$	%FS/ $^{\circ}\text{C}$
• Long Term Stability (1 year):	$\leq \pm 0.05$	Pa
• Response time:	≤ 1	mS
• Pressure Overload:	100	kPa
• Pressure Cycles (Zero to Full Scale):	10+	Million
• Compensated Temperature:	-20 ~ +85	$^{\circ}\text{C}$

Power

• Power Supply:	Built-in Replaceable Lithium Battery, External Power (option)	
• Rated Voltage	3.6	V
• Battery Lifetime:	Typ. 50,000+ readings / 10,000+ transmission (connected to ellenex platform and standard network quality)	

Physical Specification

• Media Compatibility:	Air, Inert Gas	
• Process connection:	NPT1/8" Female (or others on request)	
• Weight:	~450	g
• Protection Rate:	IP66, UV Protected	-

PDT2-N Spec-sheet

Communication

• SIM Card Type	4FF Nano-SIM, from any Network Provider
• Firmware Update:	Over The Air, Locally via Wireless Connectivity
• Sampling Period:	Configurable via downlink (default 4 hours)
• Power Consumption:	Power Saving: < 5uA, Transmission: < 220mA
• Communication Standards	Cat-NB1 (NB-IoT) Cat-M1 (option of back support by GPRS)
• Communication Bands	B1/B2/B3/B4/B5/B8/B12/B13/B18/B19/B20/B26/B28 and B39
• Data Rates:	Cat-M1: 375Kbps (DL)/375Kbps (UL) NB-IoT: 32Kbps (DL)/70Kbps (UL)
• TX Power:	23dBm
• Min Receiver Sensitivity:	Cat-M1: -107dBm / NB-IoT: -113dBm
• Antenna:	Internal (Default) / External (customised options available)
• Optional Features:	<ul style="list-style-type: none"> • Attach without PDN (Packet Data Network) • Support for IPV6 • SMS communication • Mobility support (Cat-M1 only)

NETWORK CONNECTION AND VISUALISATION

Network Integration

Pre-configured to ellenex SIM or configurable to all main narrow band networks (3, A1, AT&T, China Mobile, DU, Etisalat, KPN, M1 Singapore, Optus, Orange, Proximus, Spark, Sprint, Swisscom, Telefonica, Telstra, T-Mobile, Verizon, Vodafone, 1NCE, and any other network)

Visualization and Data Management

Ellenex white label microservice platform and Integratable to all main IIoT platforms directly or through the API (AWS, Azure, PTC ThingWorx, Bosch IoT, Cisco Jasper & Kinetic, Sierra Numerex, MathWorks ThingSpeak, GE Digital Predix, LandisGyr, Siemens MindSphere, Cumulocity, myDevices, Ubidots, TagIO, HPE IoT and any other major IoT platform).

Ellenex Platform Main Features

- Encrypted ultra-low power communication protocol with Advanced device inventory
- Integration APIs for enterprise systems
- White-label platform for enterprise runs on private account
- Multi-tenant role-based access control
- Variable alarm setting for high and low thresholds and multi-channel alerting
- Sampling and transmission interval configuration
- Transmission condition configuration
- Other configurations and customization available on request



Encrypted & ultra-low power



Integratable



Dynamic alerting



Multi-tenant



Scalable

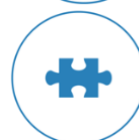

Composable & API first

PDT2-N Spec-sheet

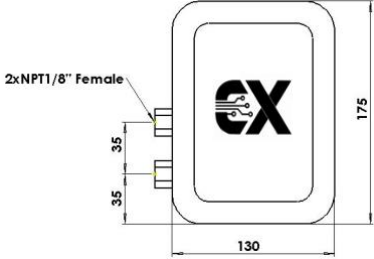
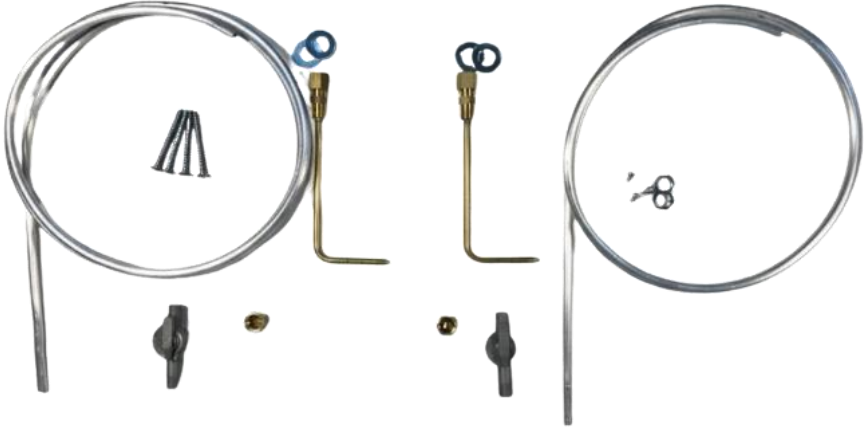
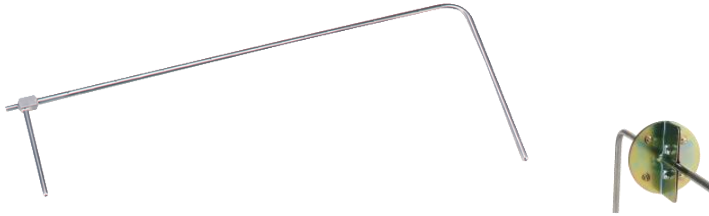

MODEL GUIDE

Standard Model	Drawing
	
<p>Installation kit (optional) For differential pressure monitoring (Static pressure tip, connector, valve)</p>	
<p>Installation kit (optional) For airflow monitoring (Pitot tube with static and dynamic pressure tip, assembly plate)</p>	

INDUSTRIES



Smart Building & HVAC



Food & Beverage



Oil & Gas



Transport & Logistics



Mining & Construction



Hydraulics and Compressed Air Systems

APPLICATIONS

- HVAC and Air Conditioning Systems
- Air Filter Performance Monitoring
- Fan and Ventilation System Performance Monitoring
- Pressurised Chambers Monitoring
- Clean Rooms positive pressure indication
- Burner and Boiler Monitoring Systems
- Leakage Monitoring Systems
- Heat Recovery Systems
- Air velocity monitoring
- Blower vacuum monitoring
- Fan pressure indication

PDT2-N Spec-sheet

ORDERING CODE

PDT2-N						
Communication Type						
B: NB-IoT			C: Cat-M1			
Pressure Range						
±500Pa (standard), ±125Pa (or any other positive or negative ranges)						
Process Port						
NPT1/8(1/8" NPT female)			Others as specified			
Device Activation						
S: on/off switch			X: No switch (always on)			
Antenna						
I: Internal			E: External			
Options						
(On request) ¹						
PDT2-N	B	500Pa	NPT1/8	S	I	

Sample Product Code:

- **PDT2-N-B-500Pa-NPT1/8-S-I**

NB-IoT differential pressure sensor operated, range of 500Pa, process connection of NPT1/8 female, activated by on-off switch and internal antenna.

¹) Product Options:

- **EPB:** sensor with external power supply connector for 12V supply with internal battery backup
- **HG:** high-gain external antenna
- **HCB:** high-capacity battery (only for E type enclosure)